

Extruded Aluminum Louver • 6" Deep • 35° Straight Blades • Combination Adjustable • Concealed Mullion

Standard Construction and Materials

FRAME: .081" thk. (nominal) extruded aluminum, 6063-T52/T6 alloy.

BLADES: Stationary blades are .081" thk. (nominal) extruded aluminum 6063-T52/T6 alloy. Adjustable blades are .125" thk. (nominal) extruded aluminum 6063-T52/T6 alloy. Blades are approximately 4 1/2" on centers.

LOUVER FACE: Full width sill with head and blades contained within jambs. Concealed mullion with continuous length stationary blade.

LINKAGE: Extruded aluminum, concealed in the channel out of the airstream. The pivots, which rotate in Celcon bearings, are .50" dia. Zinc plated machined steel. The pivot is locked to the 3/16" dia. aluminum linkage rod by a 1/4" - 20 set screw with epoxy locking patch.

BEARINGS: Celcon bearing material so there will be no metal to metal scraping.

SHAFTS: .50" dia. aluminum "Pin-Lock" rod.

SEALS: Extruded silicone rubber seals at blade edge. Foam on bottom blade and polycarbonate jamb seals. Standard stainless steel at jambs required on painted louvers.

SCREEN: (When indicated, in a removable frame)

1/2" flattened aluminum, .051" thk.,

-or- Insect screen 1 1/8" aluminum mesh, .011" dia.,

-or- 1/2" sq. mesh intermediate double crimped aluminum wire, .063" dia.

FINISH: Mill.

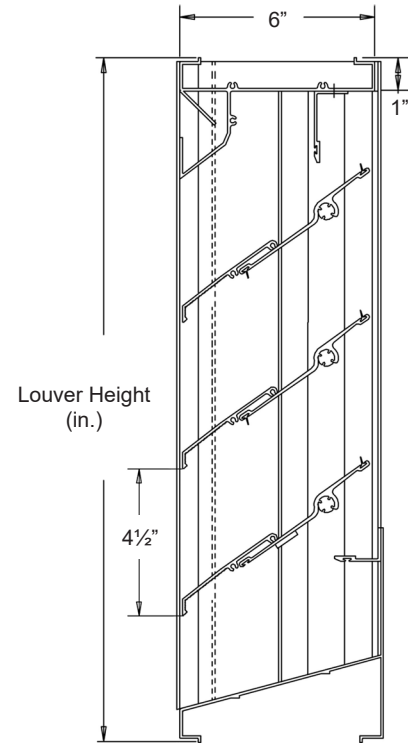

Not to scale

Options

Finishes - Enamels, Epoxies, etc.

Other screens available.

Actuators - Electric, Pneumatic, Manual, etc.

Notes

1. 1/2" nominal deduction will be made to the opening size given.
2. Approximate shipping weight is 5.0 lbs./sq.ft.

Louver Sizes

Min Panel	Max Single Panel
12"W x 16"H	96"W x 72"H

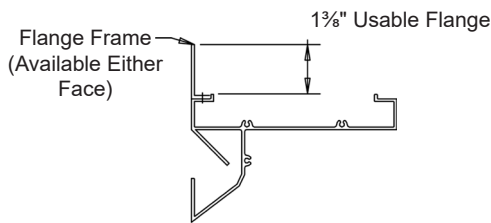

Flange Frame Available

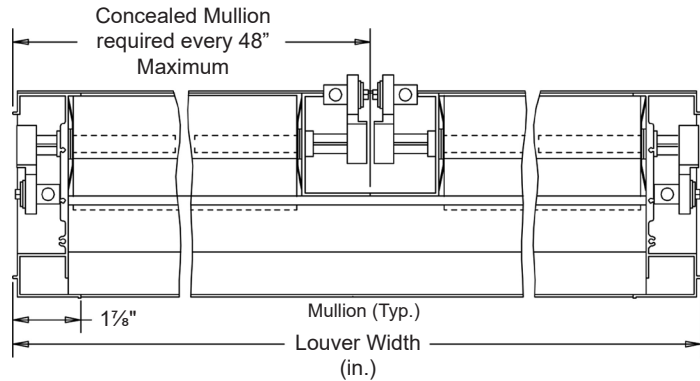

* Visible Mullion required every 96" maximum.

Item #	Qty	Width	Height	Width	Height	Mullion	Type	Location		
		Opening Size		Louver Size			Screens			Union Made
Arch. / Eng.:						EDR:		ECN:		Job:
Contractor:										
Project:						Date:		DWN:		DWG:

In the interest of product development, Cesco Products reserves the right to make changes without notice.



450 Riverside Dr • Wyalusing PA, 18853
 Phone: 570-746-1888 • Fax: 570-746-9286
 www.cescoproducts.com